

中电实业  
CHINA POWER IND.

5KW

Solar Power System Solution

# CONTENTS

## CONTENTS

1

**PROJECT SITE**

2

**SYSTEM DIAGRAM**

3

**SYSTEM INTRODACTION**

4

**LOAD-USING TIME**

5

**AFTER-SALES SERVICE**

## project site

Ø longitude: 22.22

Ø latitude: 91.48

Ø sunshine: 5 hours/day

Ø Annual mean temperature : 26.5 °C

Ø: annual rainfall 1500 mm

Ø local applicable voltage: 220V 1P,  
50Hz

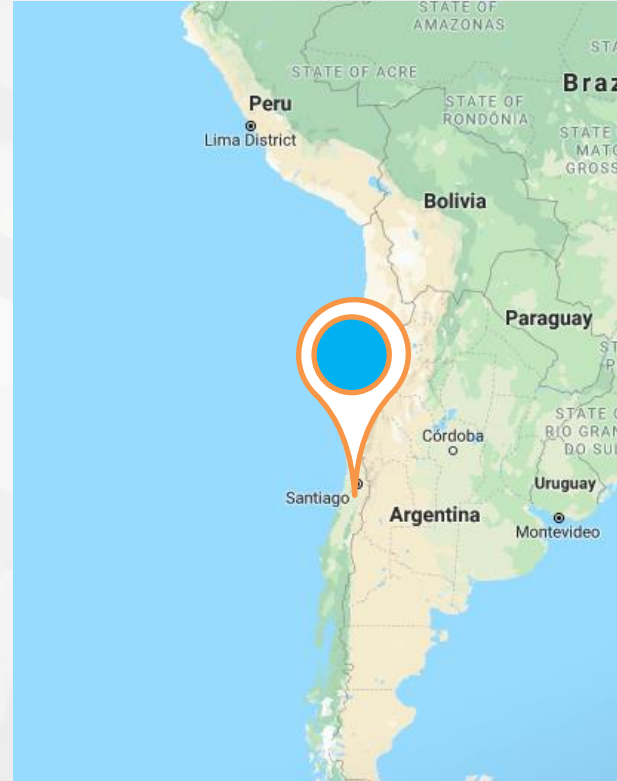

## CLIMATIC CHARACTERISTICS

Because the country spans 38 latitudes and the geographical conditions of each region are different, Chile's climate is complex and diverse, including various forms, making it difficult to summarize the climate of Chile in one sentence. The climate can be divided into three distinct sections: north, middle and south. The middle part is a subtropical Mediterranean climate with rainy winter and dry summer. The south has a rainy temperate broad-leaved forest climate. According to the cobain classification of climate, there are at least seven major climate subtypes in Chile, including deserts in the north, alpine tundra and glaciers in the east and southeast, humid subtropical climate on Easter island, maritime climate in southern Chile and Mediterranean climate in central Chile. Most parts of the country have four seasons: summer (December to February), autumn (march to may), winter (June to August) and spring (September to November).

# System diagram



**5KW  
system**

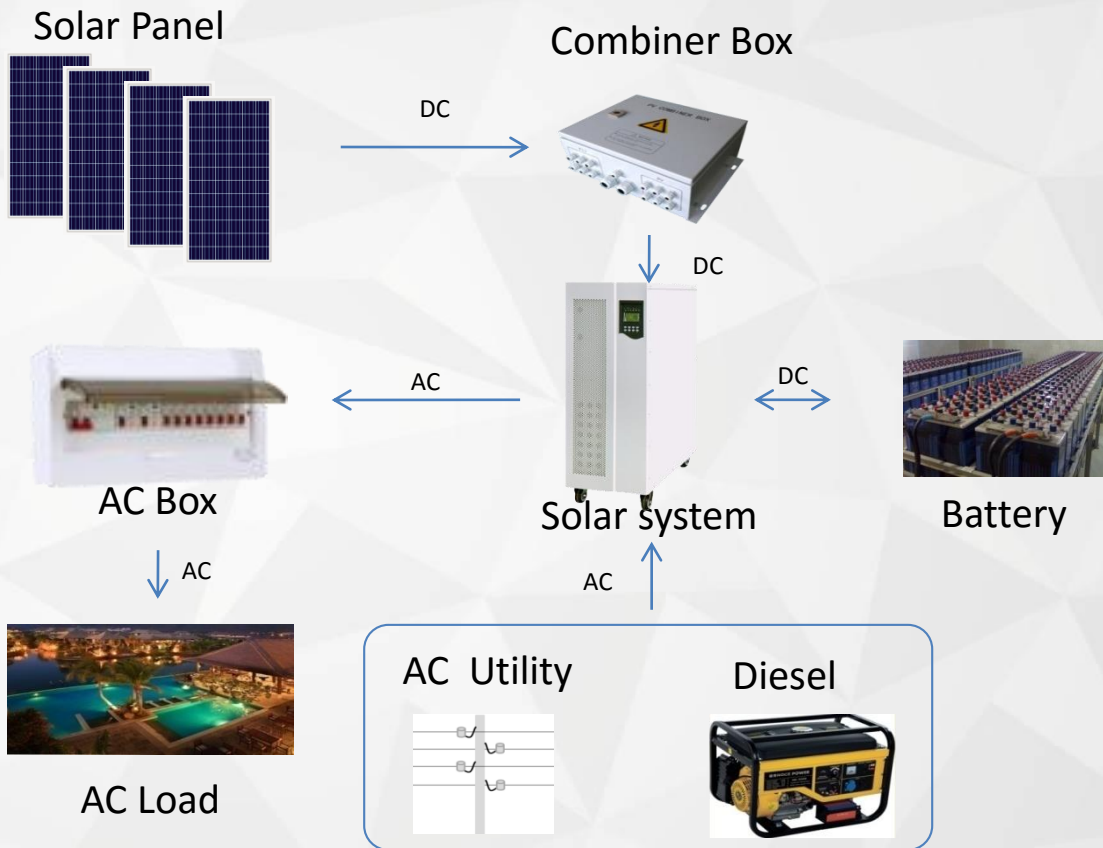

# SCOPE OF BUSINESS

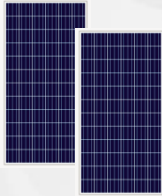

Solar photovoltaic modules



Solar panel bracket



PV Combiner box



Diesel



Controller & Inverter  
Solar System



Battery



PV Cable



AC Box

## features

### Features:

- Ø MPPT controller, maximize utilization of solar panels
- Ø Low frequency transformer isolation design, output stable
- Ø Pure sine wave THD<3%
- Ø Multipurpose extensible
- Ø AC Utility/diesel generator input (optional)
- Ø Excellent overload capacity
- Ø Suitable for all sorts of electrical appliances
- Ø Intelligent battery management function
- Ø Complete protections
- Ø LCD display + LED status indicator
- Ø IP20
- Ø Warranty: 2 Years



# POWER SYSTEM

5KW

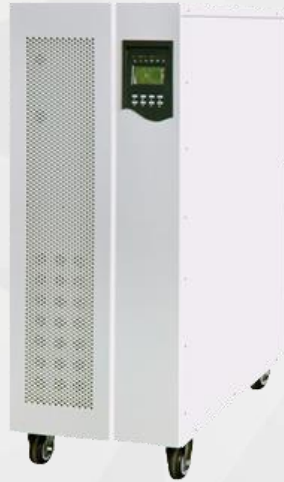

Specification	Model No.	CSL6K-296
AC Output	Rated output power	5KW
	Output waveform	Pure Sine Wave
	Output voltage	220/230/240VAC±5%
	Output frequency	50/60±1%
	Output waveform distortion (THD)	≤3%
	Inverter efficiency (80% resistive load)	≥85%
	Current peak factor	03:01
	Overload capacity	105-110%, 600S; 110-125%, 60S; >125%, 1S
	Battery	Rated voltage (VDC)
Float voltage (VDC)		108
Charge voltage (VDC)		113.6
PV Input	Controller Type	MPPT
	Maximum input power (kWp)	5.7(96V)
	Start Voltage (VDC)	140
	The maximum input voltage (VDC)	300
	MPPT Voltage Range (V)	130~280
	The recommended operating voltage (VDC)	150~260
AC Bypass	Input voltage range (Vac)	220/230/240VAC±15%
	Input Frequency (Hz)	50/60±3%
	Transfer time	10ms
	Diesel trigger signal	Dry port (Optional)
	AC Bypass Charger(Optional )	Standard : 5A (Optional)
Display & Proteciton	Display mode	LCD+LED
	Protection	Input reverse polarity protection, input under-voltage protection, input overvoltage protection, output overload protection, output short circuit protection (no automatic recovery, the need to restart the machine), overheating protection
	communication	RS485(optional)
Environment	protection degree	IP20
	Using altitude (m)	≤5000 ( 1000m above derating 1% per 100m.)
	Permissible relative humidity	<95% No condensation
	Ambient Temperature (°C)	-10 ~ +50
	Noise (1m)	≤55dB
SIZE & WEIGHT	Width x depth x height (D x W x H) mm	305*630*780mm
	Weight (Kg)	80kgs



# COMBINER BOX



PV INPUT :	4mm <sup>2</sup>
PV OUTPUT:	10mm <sup>2</sup>
Ground:	8mm <sup>2</sup>
Voltage :	500V

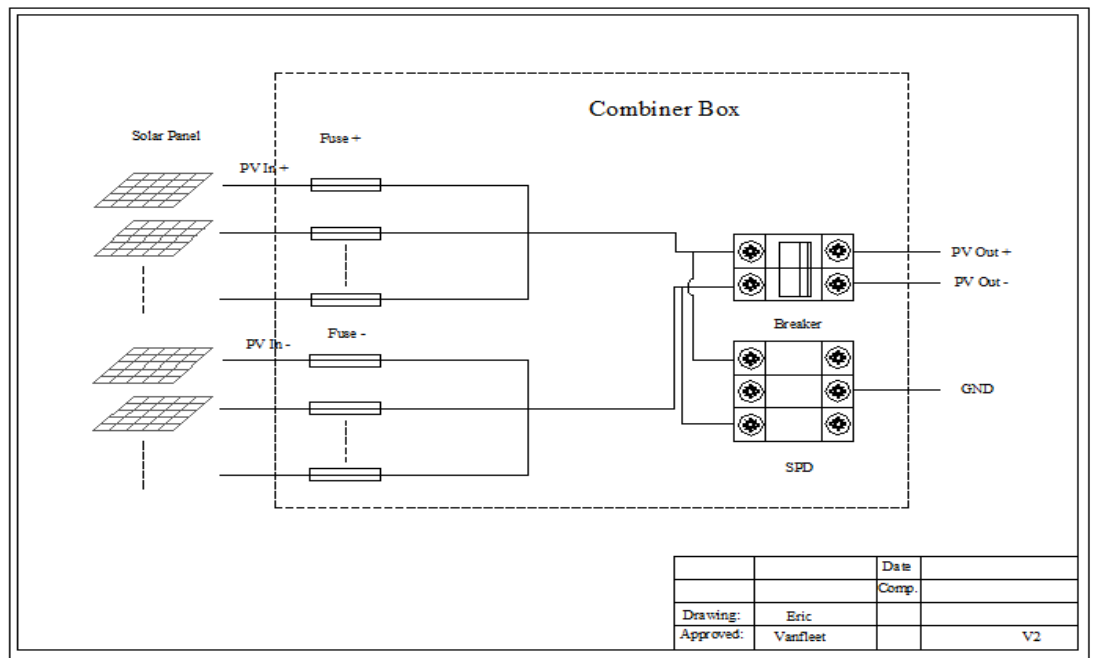

# solar panel spec

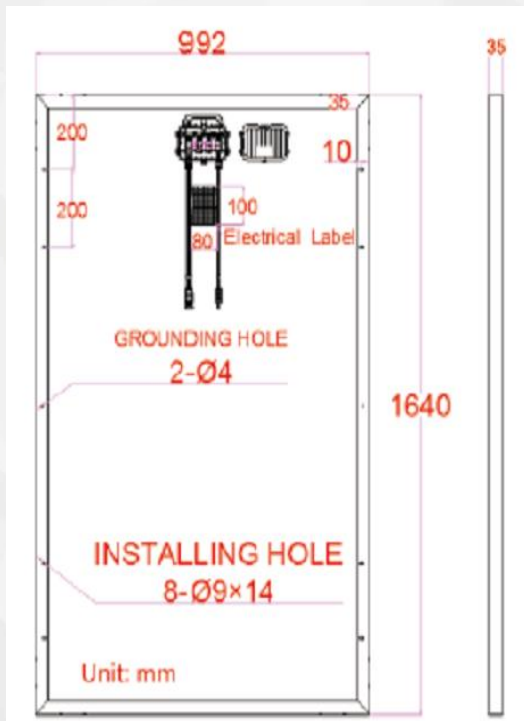
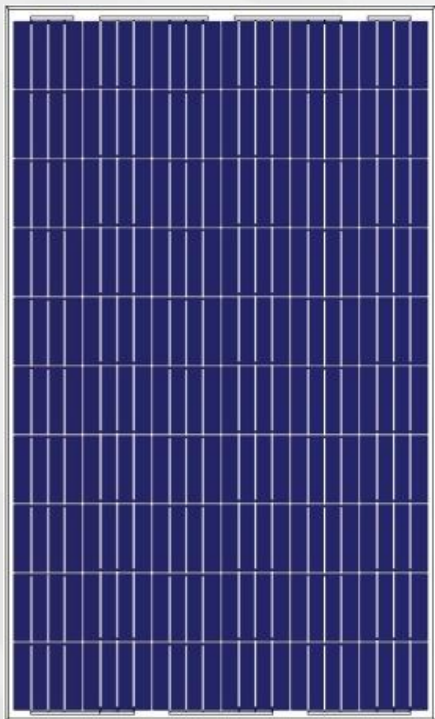

### V-A Curve Chart

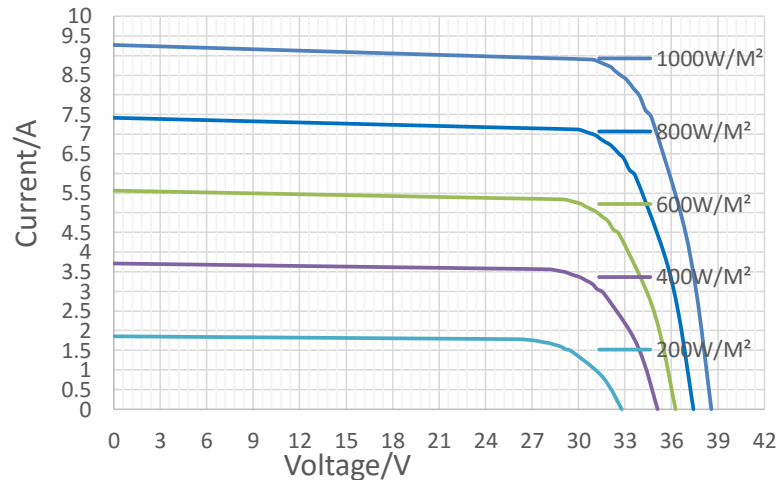

# project site

## Characteristics

	SPM-270PB205	SPM-275PB205	SPM-280PB205
Maximum power(Pm) :	270.0 W	275.0 W	280.0 W
Power Tolerance:	-0 +3%	-0 +3%	-0 +3%
Voltage of Max power(Vmp) :	32.10 VDC	32.13 VDC	32.40 VDC
Current at max power(Imp):	8.41 A	8.56 A	8.64 A
Open circuit voltage(Voc):	37.56 VDC	37.59 VDC	37.91 VDC
Short circuit current(Isc):	9.00 A	9.16 A	9.25 A
Solar panel efficiency:	16.60 %	16.90 %	17.21 %
Operating Temperature:	-40°C to +85°C		
Maximum System Voltage:	1000 VDC		
Max. series fuse rating	12 A		
Standard Test Condtion:	Irrandiance 1000W/M²,AM=1.5 ,Module temperature 25°C		

## Mechanical Characteristics

Solar cell :	Polycrystalline silicon solar cell 156*156mm				
No.of cells and connections :	6	*	10	=	60 PCS
Dimension of module:	1640	*	992	*	35 mm
Junction Box :	Ip65 rated				
Cable&Connector:	L=0.9M 4mm² PV Cable & MC4 Connector				
Warranty :	Pm is not less than 90% in 10 years and 80% in 25 years				
Resistances :	227g stell ball fall down from 1m height and 60m/s wind				

## Environmental Characteristics

Noct :	48 ± 2	°C
Current temperature coefficient :	0.05±0.01	%/K
Voltage temperature coefficient :	-0.33±0.01	%/K
Power temperature coefficient :	-0.42±0.05	%/K

## Packing Information

No. of solar panel per carton:	NA PCS
Carton size:	NA mm
Weight per panel :	17.2 Kg
Pallet size:	1670*1120*1110 mm
No. of solar panel per pallet:	30 PCS
Pieces per 20ft GP:	360 PCS
Pieces per 40ft GP:	840 PCS

# BATTERY SPECIFICATION

## Feature

DC-C series lead-carbon batteries use functional activated carbon and graphene as carbon materials, which are added to the negative plate of the battery to make lead carbon batteries have the advantages of both lead-acid batteries and super capacitors. It not only improves the ability of rapid charge and discharge, but also greatly prolongs the battery life, more than 2000 cycles at 80%DOD. It is more suitable for the application of PSOC.

## Specification

<b>Cells Per Unit</b>	6
<b>Voltage Per Unit</b>	12
<b>Capacity</b>	225Ah@20hr-rate to 1.75V per cell @25°C
<b>Weight</b>	Approx. 66.0 Kg (Tolerance±1.5%)
<b>Internal Resistance</b>	Approx. 3.7 mΩ
<b>Terminal</b>	F10(M8)/F16(M8)
<b>Max. Discharge Current</b>	2250A (5 sec)
<b>Design Life</b>	15 years
<b>Maximum Charging Current</b>	90.0 A
<b>Cycle Use Voltage</b>	13.8 V~14.0 V @ 25°C Temperature Compensation: -4mV/C/Cell
<b>Operating Temperature Range</b>	Discharge: -20°C~60°C Charge: 0°C~50°C Storage: -20°C~60°C
<b>Normal Operating Temperature Range</b>	25°C±5°C
<b>Self Discharge</b>	The batteries can be stored for up to 6 months at 25°C and then recharging is recommended. Monthly Self-discharge ratio is less than 4% at 25°C. Please charged batteries before using.
<b>Container Material</b>	A.B.S. White/Red. UL94-HBUL94-V0.



## Application

- ◆ Home energy storage system
- ◆ Smart power grid and micro-grid system
- ◆ Distributed energy storage system
- ◆ Solar and wind energy storage system
- ◆ Solar power generation grid or off-grid energy storage system
- ◆ Generation and battery hybrid energy storage system
- ◆ .....



## Constant Current Discharge Characteristics :A(25°C)

F.V/Time	1HR	2HR	3HR	4HR	5HR	8HR	10HR	20HR	48HR	72HR	100HR	120HR
1.60V	124.8	73.1	54.4	43.1	36.3	24.8	21.7	11.74	5.03	3.44	2.53	2.16
1.65V	122.4	71.8	53.6	42.5	35.9	24.5	21.5	11.63	4.98	3.41	2.51	2.13
1.70V	119.3	70.2	52.5	41.7	35.3	24.1	21.2	11.47	4.91	3.36	2.47	2.10
1.75V	115.0	67.9	50.9	40.6	34.4	23.6	20.8	11.25	4.82	3.30	2.43	2.06
1.80V	109.2	64.8	48.8	39.1	33.3	22.9	20.3	10.94	4.68	3.21	2.36	2.01
1.85V	100.8	60.3	45.8	36.9	31.6	21.9	19.4	10.50	4.49	3.08	2.26	1.93

## Constant Power Discharge Characteristics : WPC(25°C)

F.V/Time	1HR	2HR	3HR	4HR	5HR	8HR	10HR	20HR	48HR	72HR	100HR	120HR
1.60V	233.3	138.5	103.9	82.7	70.0	48.4	42.7	23.1	9.88	6.76	4.98	4.24
1.65V	231.3	137.1	102.9	82.0	69.5	48.0	42.4	22.9	9.80	6.71	4.94	4.20
1.70V	226.2	134.4	101.1	80.7	68.5	47.3	41.8	22.6	9.67	6.62	4.87	4.15
1.75V	219.2	130.7	98.6	78.9	67.1	46.4	41.1	22.2	9.50	6.51	4.79	4.07
1.80V	209.1	125.3	94.9	76.2	65.1	45.1	40.0	21.6	9.26	6.34	4.66	3.97
1.85V	194.4	117.3	89.4	72.2	62.0	43.2	38.5	20.8	8.89	6.09	4.48	3.81

# BATTERY SPECIFICATION

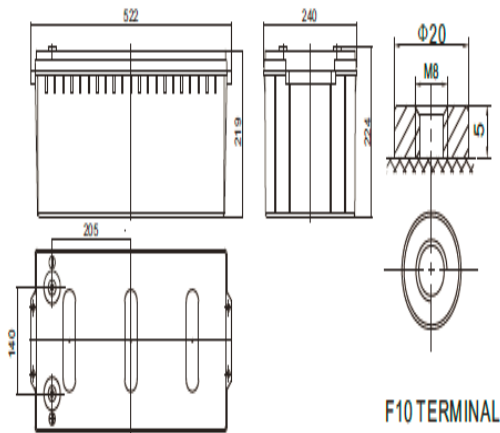

Unit: mm

Length	522±2mm (20.6 inches)
Width	240±2mm (9.45 inches)
Height	219±2mm (8.62 inches)
Total Height	224±2mm (8.82 inches)
Terminal	Value
M5	6~7 N*m
M6	8~10 N*m
M8	10~12 N*m

## Reference Capacity

Hour Rate	C20 (Ah)	C72 (Ah)	C100 (Ah)	C120 (Ah)
F.V (V/Cell)	1.75	1.85	1.85	1.85
Capacity (Ah)	225.0	221.8	226.0	231.6

## Characteristic Curve

Discharge Characteristics Curve

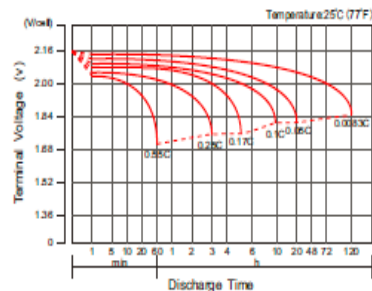

Charge Characteristic Curve for Cycle Use(IU)

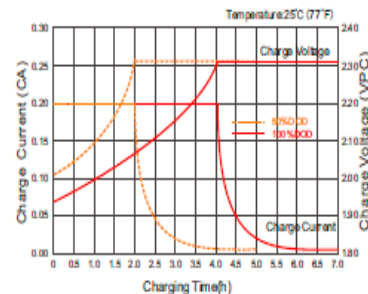

Effect of Temperature on Long Term Life

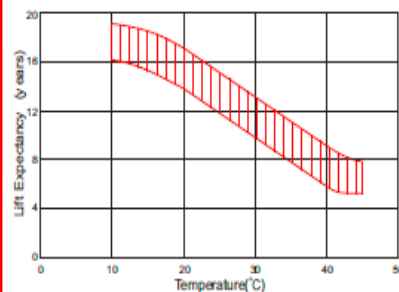

Cycle Life in Relation to Depth of Discharge

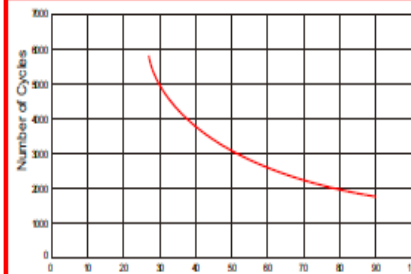

# System 3D View Ground Installation

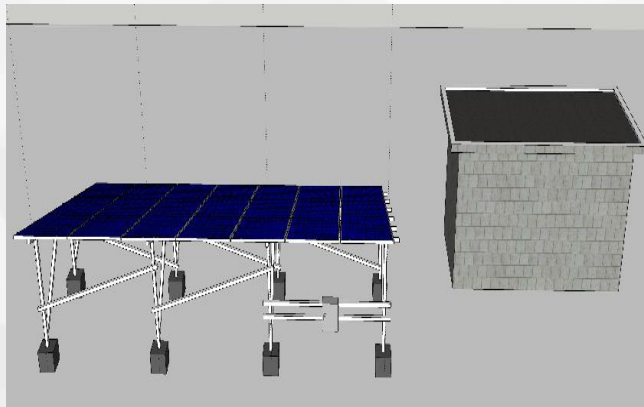
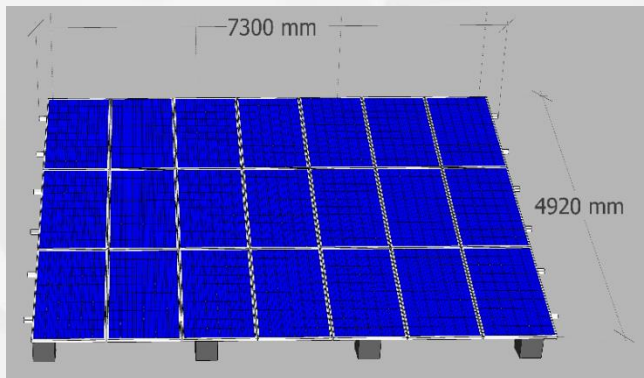
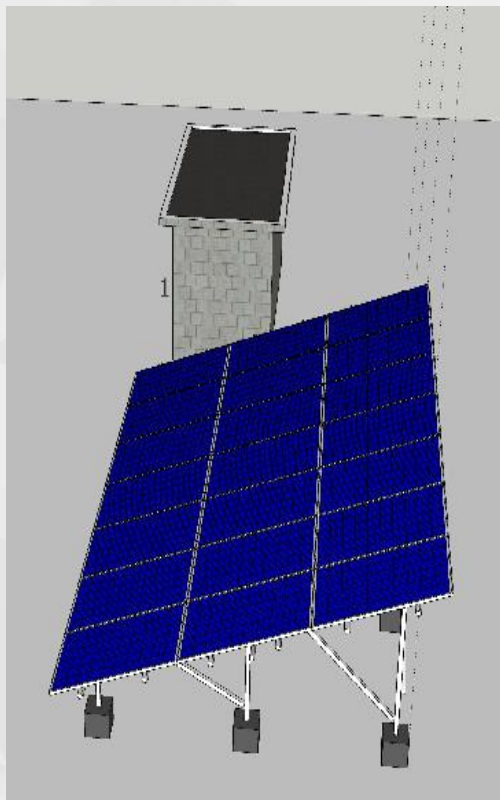

## Size and volume

Item	(L*W*H)
Panel Array	7300*4920*2100mm
Combiner Box	400*300*153mm
Solar System	600*305*800mm
AC Box	240*200*95mm
Battery Bank	1130*700*680mm

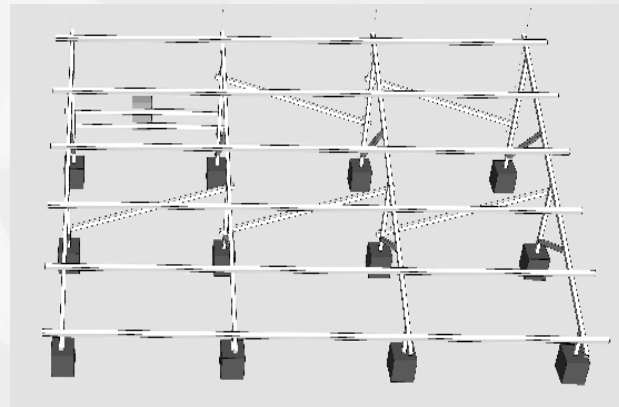

# System 3D View Roof Installation

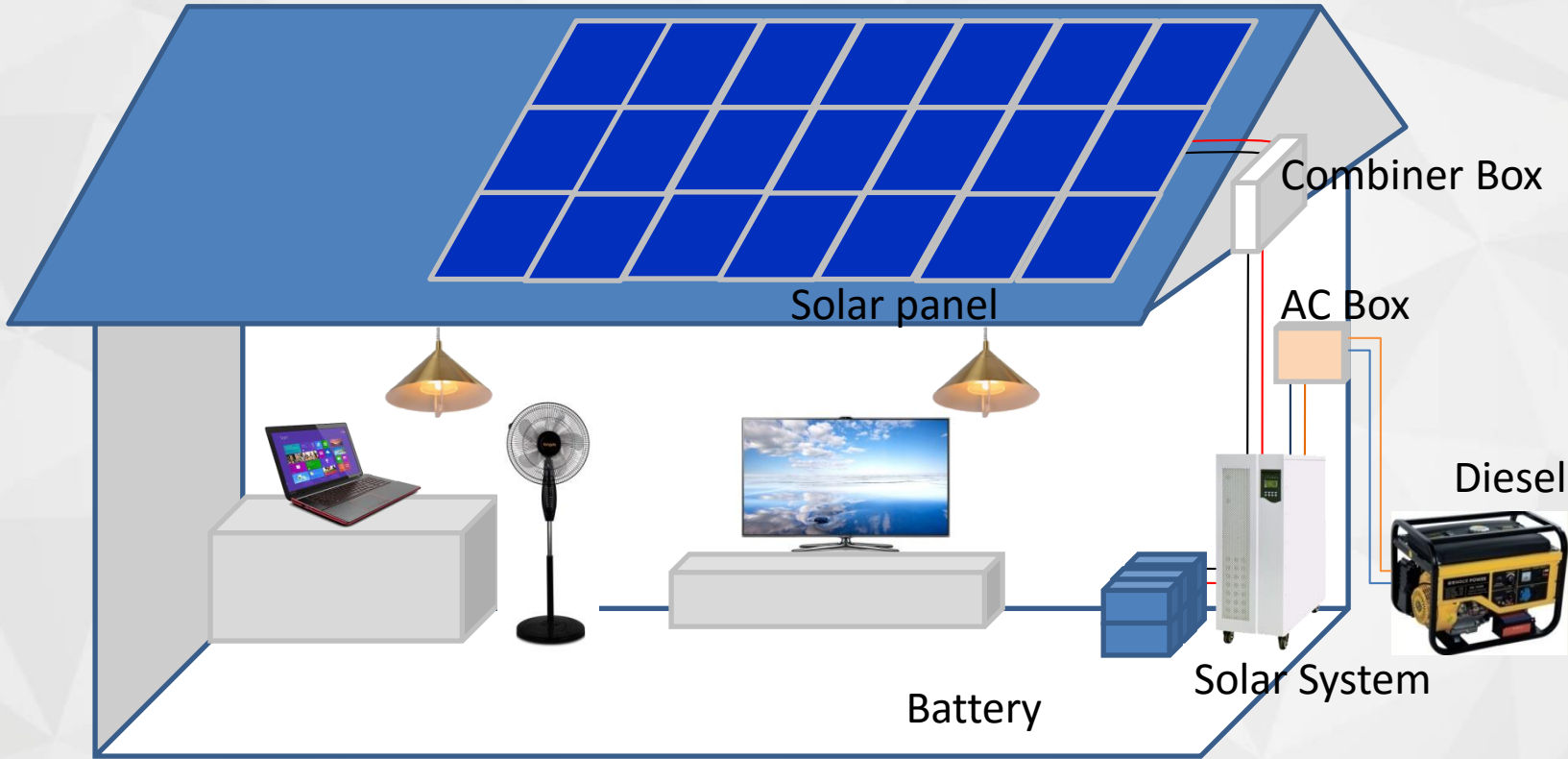

## System Detail

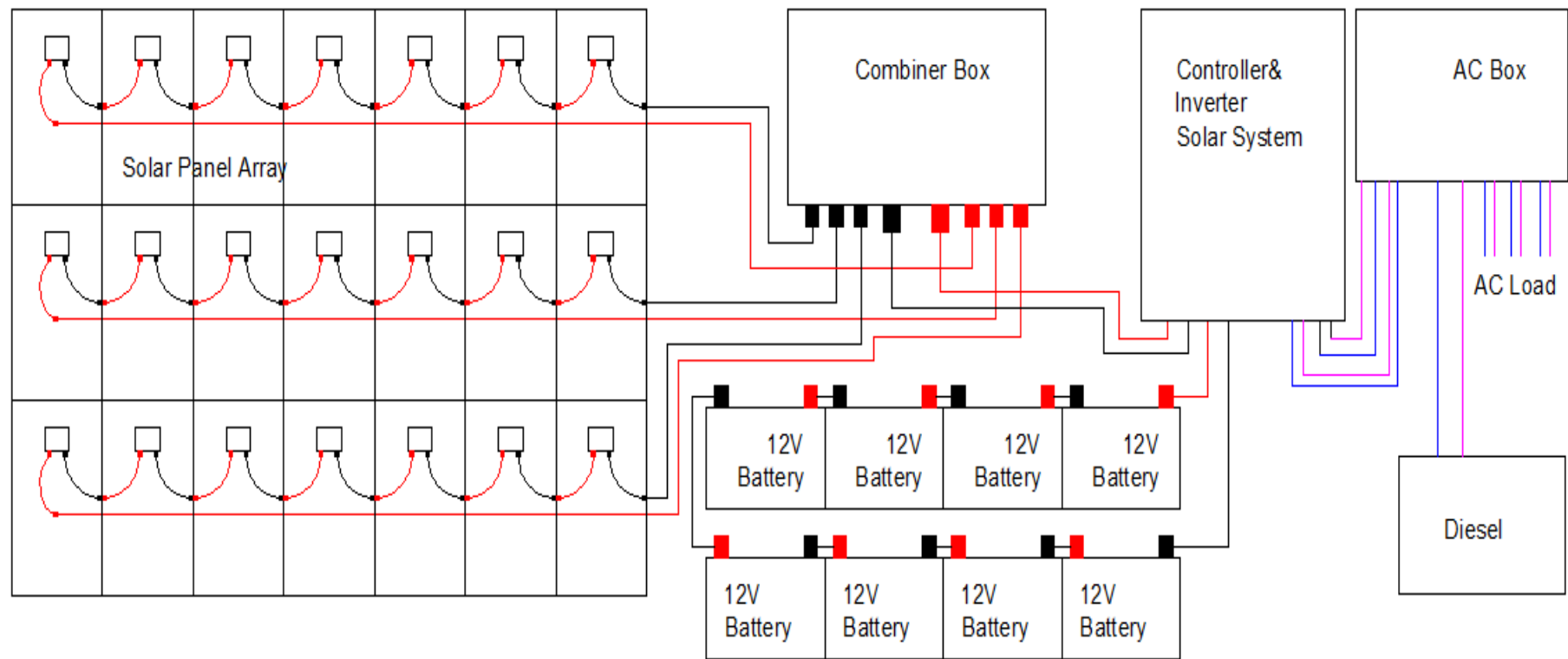



## SYSTEM CONFIGURATION TABLE

No.	Item	Description	unit	Quantity
1	Solar Panel	270Wp,31V,7S,3P=5670W	PCS	21
2	PV Combiner Box	IN:3 OUT:1, 500V	PCS	1
3	Solar Power System Inverter	5KW, 96VDC, 1P, 220VAC/50HZ	PCS	1
4	MPPT Controller	50A, 1 Way Input, With in Solar system	PCS	
5	Solar Panel Bracket	5670W	Set	1
6	Battery	12V/225AH*8pcs=96VDC	PCS	8
7	Battery Bracket	12V/225AH*8pcs	set	1
8	Output AC BOX	5KW	Set	1
9	Cable	All	Set	1
10	Auxiliary Material	All	Set	1

## System Cable Table

No.	Item	Description	unit	Quantity
1	Solar Panel to Combiner Box	4mm2 red 4mm2 black	M	50 30
2	Combiner Box to Solar System	10mm2 red 10mm2 black	M	20 20
3	Solar System to Battery	16mm2 red 16mm2 black	M	3 3
4	Solar System to AC Box	4mm2 red 4mm2 black	M	5 5
5	By pass to Solar Inverter( Bypass is AC Utility or Diesel )	4mm2 red 4mm2 black	M	5 (User) 5 (User)

## load-using time

Electricity Load and working time for 225AH Battery			
Load Power		Working time	Hour
250	W	60.5	H
500	W	30.2	H
1000	W	15.1	H
1500	W	10.1	H
2000	W	7.6	H
2500	W	6.0	H
3000	W	5.0	H
4000	W	3.8	H
5000	W	3.0	H

# packing list for 20 container

5KW System 6 Sets

No.	Item	unit	Quantity	Volume(L*W*H) CM	N.W(KGS)	G.W.(KGS)	Total (KGS)
1	Solar Panel	PCS	6	167*102*100	370	390	2340
2	PV Combiner Box	PCS	6	45*40*21	8	9	54
3	Solar Power System Inverter & MPPT Controller	PCS	6	68*40*94	82	90	540
5	Solar Panel Bracket	Set	6	300*35*35	150	180	1080
6	Battery	PCS	48	53*24*23	66	70	3360
7	Battery Bracket	set	6	113*70*40	100	110	660
8	Output AC BOX	Set	6	30*24*12	1.2	1.6	9.6
9	Cable	Set	6	60*30*30	36	40	240
10	Auxiliary Material	Set	6	60*30*30	36	40	240

20"Container

8524

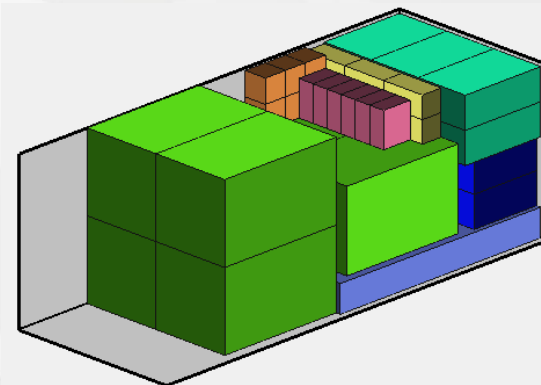
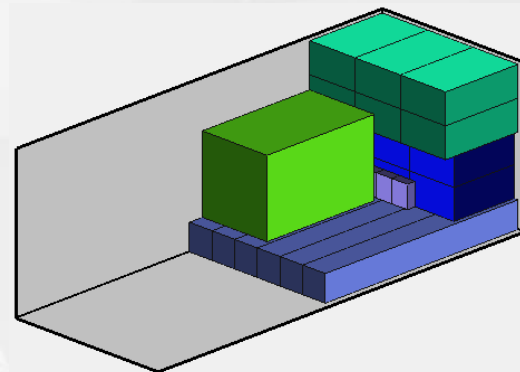

# packing list for 40 container

5KW System 15 Sets

No.	Item	unit	Quantity	Volume(L*W*H) CM	N.W(KGS)	G.W.(KGS)	Total (KGS)
1	Solar Panel	PCS	15	167*102*100	370	390	5850
2	PV Combiner Box	PCS	15	45*40*21	8	9	135
3	Solar Power System Inverter & MPPT Controller	PCS	15	68*40*94	82	90	1350
5	Solar Panel Bracket	Set	15	300*35*35	150	180	2700
6	Battery	PCS	120	53*24*23	66	70	8400
7	Battery Bracket	set	15	113*70*40	100	110	1650
8	Output AC BOX	Set	15	30*24*12	1.2	1.6	24
9	Cable	Set	15	60*30*30	36	40	600
10	Auxiliary Material	Set	15	60*30*30	36	40	600
							<b>21309</b>
<b>40"Container</b>							

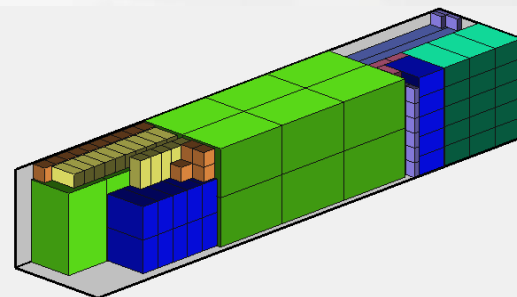
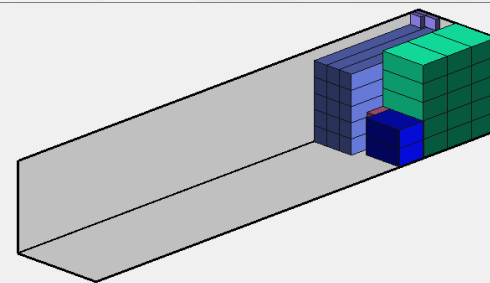

# packing list for 20 container

3KW 7 Sets 5KW 3 Sets

No.	Item	unit	Quantity	Volume(L*W*H) CM	N.W(KGS)	G.W.(KGS)	Total (KGS)
1	Solar Panel	PCS	7	167*102*60	220	250	1750
2	PV Combiner Box	PCS	7	45*40*21	8	9	63
3	Solar Power System Inverter & MPPT Controller	PCS	7	40*62*31	30	32	224
5	Solar Panel Bracket	Set	7	300*25*25	150	180	1260
6	Battery	PCS	28	53*24*23	66	70	1960
7	Battery Bracket	set	7	113*70*20	50	55	385
8	Output AC BOX	Set	7	30*24*12	1.2	1.6	11.2
9	Cable	Set	7	30*30*30	18	20	140
10	Auxiliary Material	Set	7	30*30*30	18	20	140
No.	Item	unit	Quantity	Volume(L*W*H) CM	N.W(KGS)	G.W.(KGS)	Total (KGS)
1	Solar Panel	PCS	3	167*102*100	370	390	1170
2	PV Combiner Box	PCS	3	45*40*21	8	9	27
3	Solar Power System Inverter & MPPT Controller	PCS	3	68*40*94	82	90	270
5	Solar Panel Bracket	Set	3	300*35*35	150	180	540
6	Battery	PCS	24	53*24*23	66	70	1680
7	Battery Bracket	set	3	113*70*40	100	110	330
8	Output AC BOX	Set	3	30*24*12	1.2	1.6	4.8
9	Cable	Set	3	60*30*30	36	40	120
10	Auxiliary Material	Set	3	60*30*30	36	40	120

20"Container

10195

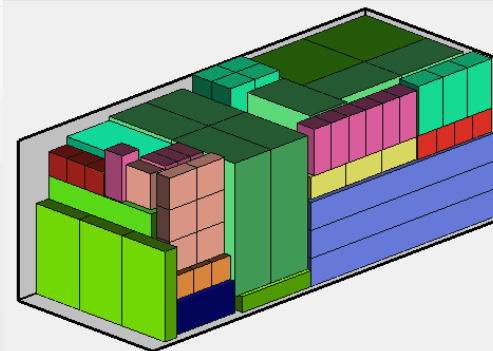
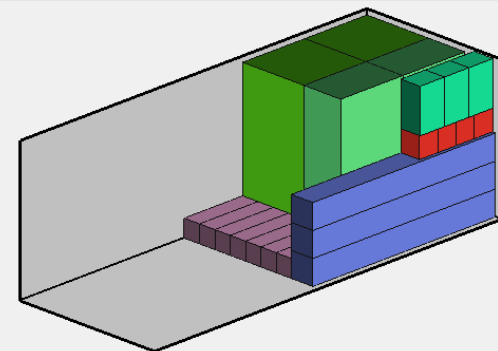

# After-sales service



# troubleshooting

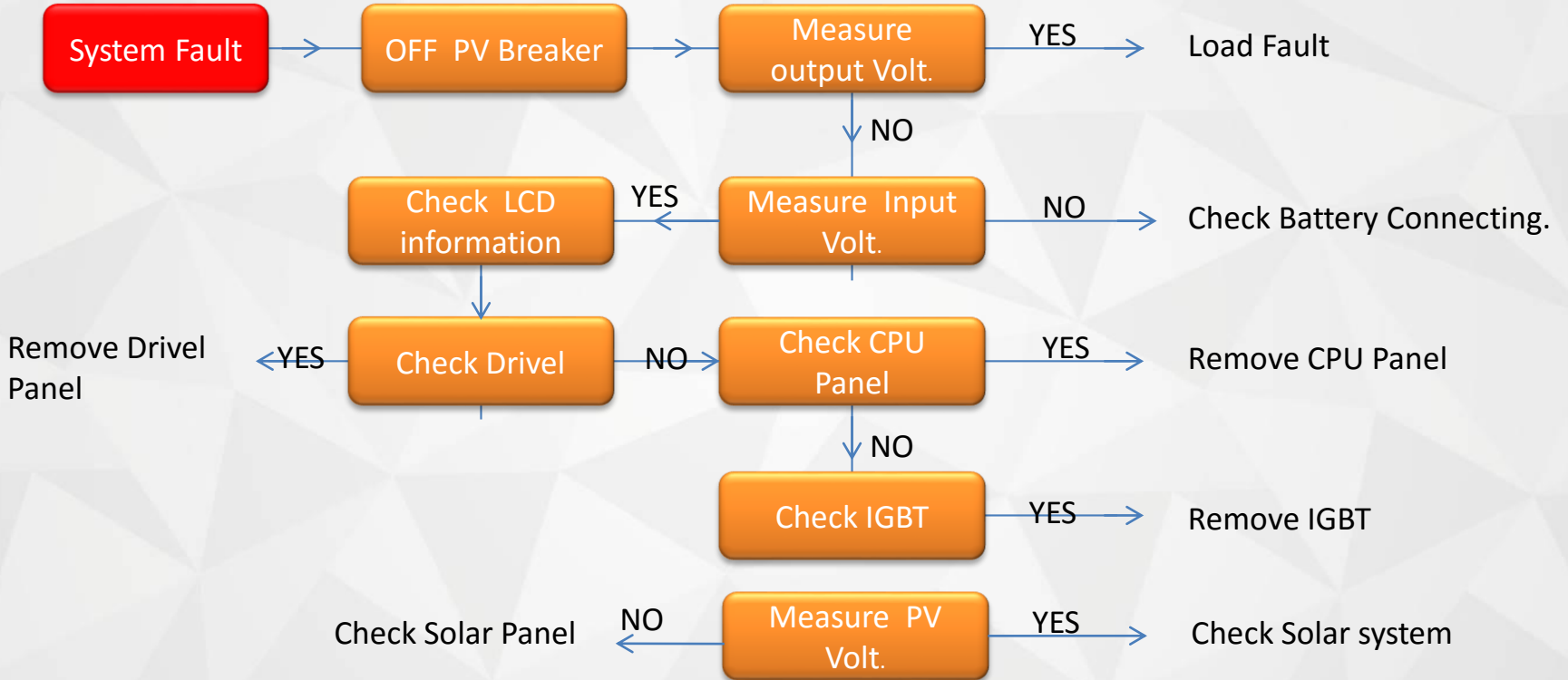



# Warranty

## Equipment Life

**PV**

25years

**Battery**

3years

**Controller**

2years

**Other**

2years

**Inverter**

2years

**AC Box**

2years

# Company qualification



# THANKS

**5KW Solar System Solution for Chile**